

## Screwing-in thermowell acc. to DIN 43772 form 5, 6, 7, 8



### Description

Thermowells in conductive materials are used to separate the thermometer from the medium.

A thermowell is particularly recommended for service with pressurized media. In addition, thermowells protect the thermometers from aggressive media and facilitate replacement of the thermometer.

An extensive range of standard versions provides for service in variety of applications.

### Features

- for thermometers with male or female thread
- for aggressive media
- Standard material: Stainless steel 1.4571
- Large selection of standard versions available
- Special materials and dimensions as required

### Versions

- fabricated (TW991, TW994)
- solid-drilled (TW992, TW995)

### Form of thermowell acc. to DIN 43772

- Form 5 – TW991
- Form 6 – TW992
- Form 8 – TW994
- Form 9 – TW995

### Options

- other materials or coverings

**Models: TW991, TW992, TW994, TW995**

## Technical Data

<b>Models</b>	TW991	TW992	TW994	TW995
<b>Type of thread</b>	for thermometers with male thread		for thermometers with female thread	
<b>Version</b>	Fabricated	Solid-drilled	Fabricated	Solid-drilled
<b>Max. process temperature <sup>1)</sup></b>	600°C	600°C	600°C	600°C
<b>Max. pressure (statical) <sup>1)</sup></b>	40bar	150 bar	40 bar	150 bar
<b>Material of thermowell</b>	1.4571			
<b>Thermometer connection</b>	G <sup>1</sup> / <sub>2</sub> , G <sup>3</sup> / <sub>4</sub>			
<b>Process connection</b>	G <sup>1</sup> / <sub>2</sub> , G <sup>3</sup> / <sub>4</sub>			
<b>Standard lengths U<sub>1</sub></b>	82, 142, 182, 232, 382mm		73, 110, 170, 210, 260mm	

1) Rating depends on the parameters process medium, process pressure and temperature, flow rate and design of thermowell. In critical applications an additional calculation is recommended.

## Correlation thermowell – thermometer for standard lengths

### TW991 / TW992

thermowell insertion length U <sub>1</sub>	thermometer stem length l <sub>1</sub>	
	connection male thread	connection male nut
45	63	---
82	100	80
142	160	140
182	200	180
232	250	230
	$l_1 = U_1 + 18\text{mm}$	$l_1 = U_1 - 2\text{mm}$

### TW994 / TW995

thermowell insertion length U <sub>1</sub>	thermometer stem length l <sub>1</sub>
	<b>Union nut</b>
73	89
110	126
170	186
210	226
260	276
	$l_1 = U_1 + 16\text{mm}$

## Dimensions

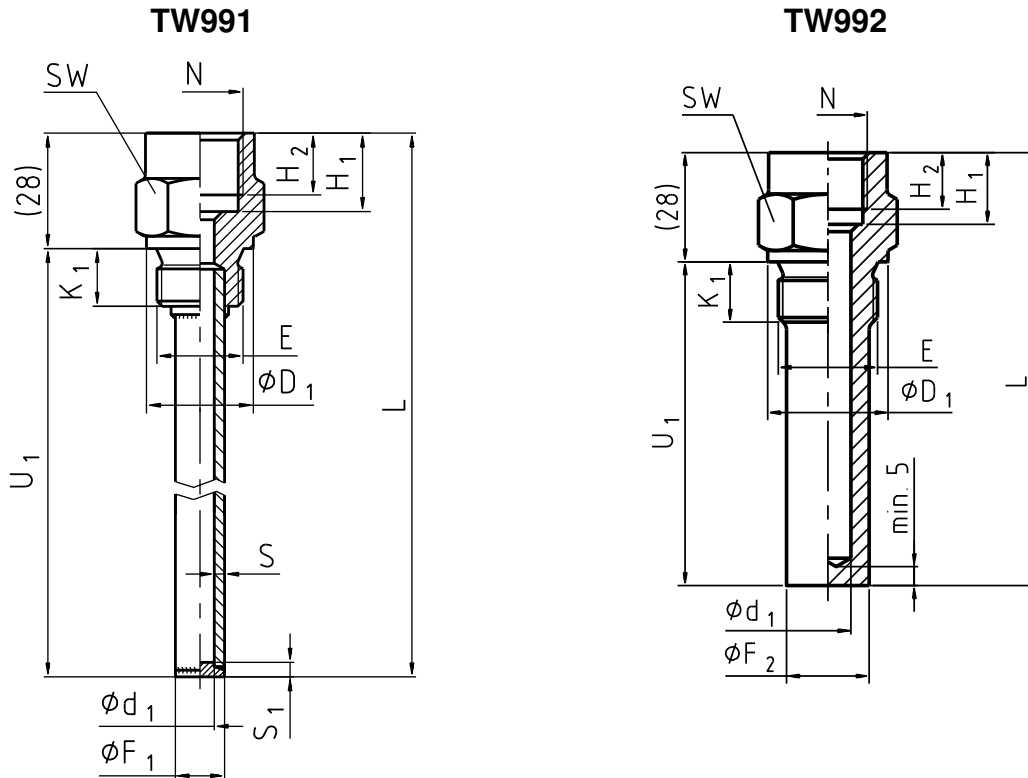

### Legend

E	Process connection	S	Wall thickness
H <sub>1</sub>	Bore depth for female thread	S <sub>1</sub>	Ground height
H <sub>2</sub>	Length of female thread	U <sub>1</sub>	Insertion length
K <sub>1</sub>	Length of male thread	Ød <sub>1</sub>	Bore size
L	Total length	ØD <sub>1</sub>	Diameter of sealing face
N	Instrument connection	ØF <sub>1</sub>	Outer diameter of thermowell
SW	Flats	ØF <sub>2</sub>	Outer diameter of thermowell

	E	N	Ød <sub>1</sub>	ØF <sub>1</sub> ; ØF <sub>2</sub>	H <sub>1</sub>	H <sub>2</sub>	K <sub>1</sub>	ØD <sub>1</sub>	S	S <sub>1</sub>	SW
TW991	G ½	G ½	6,2	8	19	15	14	26	0,9	1	27
			8,2	10							
			10,2	12							
			7	14							
			9								
11	17	---	---								
7											
9											
TW992			11								

## Calculation of thermometer- stem length

Connection design	Thermometer length l <sub>1</sub>
S fixed male thread	l <sub>1</sub> =L - 10mm    l <sub>1</sub> =U <sub>1</sub> + 18mm
2 male nut	l <sub>1</sub> =L - 30mm    l <sub>1</sub> =U <sub>1</sub> - 2mm

## Dimensions

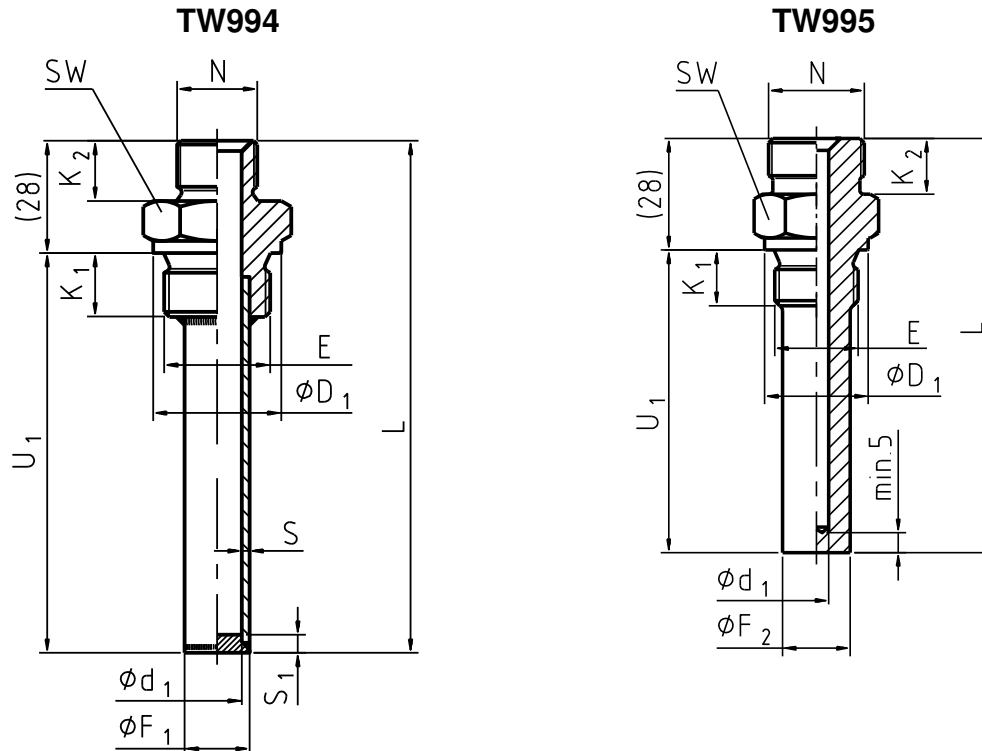

### Legend

E	Process connection	S	Wall thickness
K <sub>1</sub>	Length of male thread	S <sub>1</sub>	Ground height
K <sub>2</sub>	Length of male thread for therm. connection	U <sub>1</sub>	Insertion length
L	Total length	Ød <sub>1</sub>	Bore size
N	Connection thread for thermometer	ØD <sub>1</sub>	Diameter of sealing face
SW	Flats	ØF <sub>1</sub>	Outer diameter of thermowell
		ØF <sub>2</sub>	Outer diameter of thermowell

	E	N	Ød <sub>1</sub>	ØF <sub>1</sub> ; ØF <sub>2</sub>	K <sub>1</sub>	K <sub>2</sub>	D <sub>1</sub>	S	S <sub>1</sub>	SW
TW994	G ½	G ½	6,2	8	14	12	26	0,9	1	27
			8,2	10						
			10,2	12						
			7	14						
			9	14						
TW995			7	17						
			9							
			11							

### Calculation of thermometer-stem length

Connection design	Thermometer length l <sub>1</sub>
3 union nut	l <sub>1</sub> =L - 12mm    l <sub>1</sub> =U <sub>1</sub> + 16mm

Subject to technical modifications